

Kompakt-kulventil med hus av syrafast stål, AISI316. PN 40/16

Compact wafer ball valve in stainless steel, AISI316. PN 40/16

Kompakt-Kugelhahn mit gehäuse aus Edelstahl, AISI316. PN 40/16



ISO-5211 Direktmontage

ISO-5211 Direct mount

ISO-5211 Direkten Antriebsaufbau



Beskrivning

Kompakt-kulventil i syrafast stål för applikationer med trånga utrymmen. Lämplig på neuutrala gaser och flytande media. Ventilen är utrustad med ISO-5211 toppfläns för direktmontage av manöverdon. Utblåsnings säker spindel och självkompenserande packbox för utmärkt atmosfärisk tätning. Högglosspolerad kula och sätestätningar av glasfiberförstärkt PTFE som standard. Låsbar handspak. Anti-statisk utförande som standard.

Description

Compact wafer ball valve in acid resistant stainless steel with short face-to-face dimensions. Suitable for neutral gases and liquids. The valve is equipped with ISO-5211 top flange for direct mounting of actuators. The stem is blow-out-proof and has a self compensating packing box for excellent atmospheric tightness. A mirror polished ball and PTFE-glass fiber reinforced sealings. Lockable handle. Anti-static design.

Beschreibung

Kompakt-Wafer-Kugelhahn aus Edelstahl mit Kompakte Körperkonstruktion und geringem Gewicht. Geeignet für neutrale Gase und Flüssigkeiten. Das Ventil ist mit ISO-5211 Top-Flansch für die direkte Montage der Antriebe. Der Spindel ist Blow-out-Nachweis und verfügt über eine selbst Veredelungserzeugnisse Verpackung Box für exzellente atmosphärische Dichtheit. Ein Spiegel polierter Kugel-und PTFE-Glasfaser verstärkt Dichtungen. Abschließbarer Handhebel. Anti-statische Design.

Kompakt-kulventil med hus av syrafast stål, AISI316. PN 40/16

Compact ball valve in stainless steel, AISI316. PN 40/16

Kompakt-Kugelhahn mit gehäuse aus Edelstahl, AISI316. PN 40/16

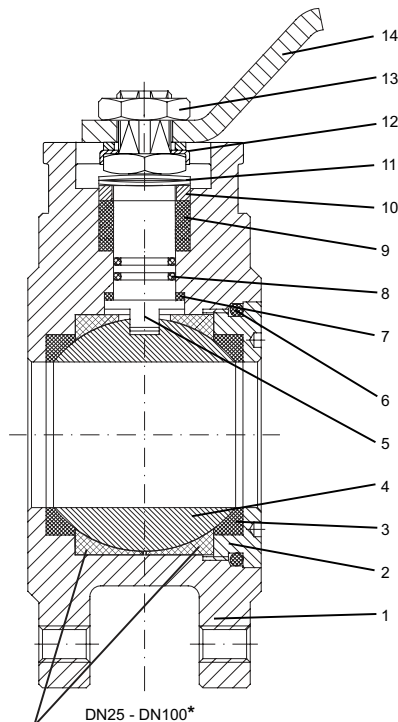

DN25 - DN100*

Teflonfyllda hålrum på förfrågan
Cavity-free version on demand
Hohlräumarme Ausführung auf Anfrage

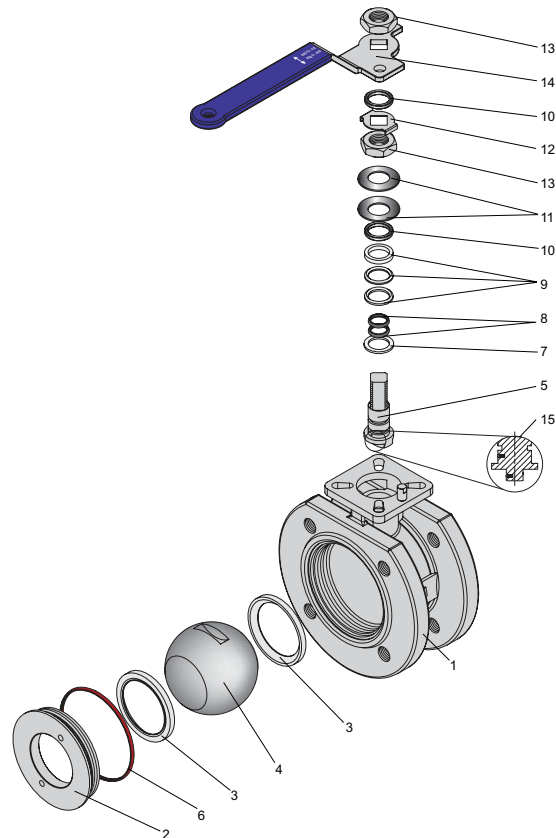

Material / Material / Material

①	Hus	Body	Gehäuse	1.4408
②	Husgavel	End cap	Verschluss	1.4408
③	Kulsäte	Ball Seats	Kugeldichtung	PTFE + 15% Glasfiber/Glassfiber/Glasfaserverstärkt
④	Kula	Ball	Kugel	1.4408 (CF8M / 316)
⑤	Spindel	Stem	Spindel	1.4408
⑥	Hustätning O-ring	Body O-ring	Gehäuse O-ring	FKM
⑦	Packning	Gasket	Dichtung	PTFE + 15% Glasfiber/Glassfiber/Glasfaserverstärkt
⑧	O-ring	O-ring	O-Ring	FKM
⑨	Spindeltätningar	Stem seals	Spindeldichtung	PTFE - Grafit/Graphite/Graphit
⑩	Glandring	Gland ring	Druckring	1.4301
⑪	Fjäderbricka	Spring washer	Tellerfeder	1.4301
⑫	Låsanordning	Locking tab	Verdrehsicherung	1.4301
⑬	Mutter	Lever nut	Mutter	1.4301
⑭	Handspak	Handle	Handhebel	1.4301 (Plastfodral/Plastic cover/Vinylummantelt)
⑮	Anti-statisk	Anti-static device	Anti-Statik Einrichtung	Rostfritt stål / Stainless steel / Edelstahl

Rätt till tekniska ändringar förbehålles. Subject to changes Änderungen vorbehalten 2010-09-20

Kompakt-kulventil med hus av syrafast stål, AISI316. PN 40/16

Compact ball valve in stainless steel, AISI316. PN 40/16

Kompakt-Kugelhahn mit gehäuse aus Edelstahl, AISI316. PN 40/16

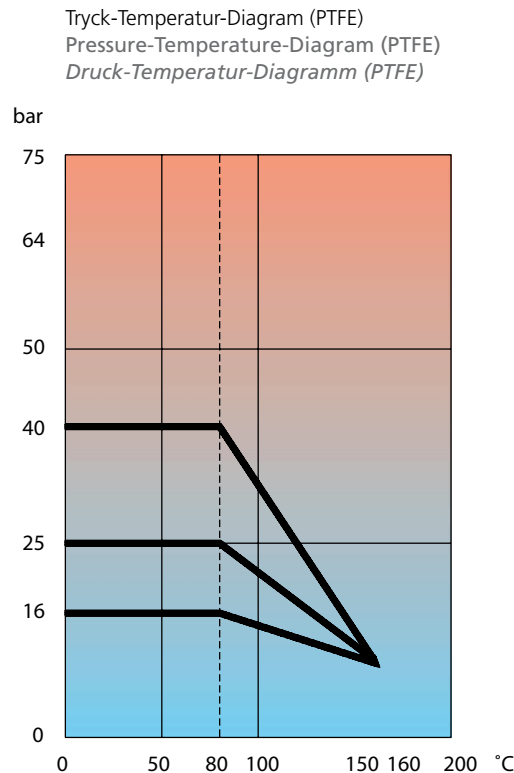

Alt.utförande / Alt.execution / Alt. Ausführung

Hus av stål	Body of carbon steel	Gehäuse aus Stahl
Hus av gjutjärn	Body of cast iron	Gehäuse aus Grauguß
Anti-bakterie utförande	Cavity-free version	Hohlraumarme Ausführung
Elektriskt manöverdon	Electric actuator	Elektrischer Schwenkantrieb
Pneumatiskt manöverdon	Pneumatic actuator	Pneumatischer Schwenkantrieb

Teknisk data / Technical data / Technische Daten

Max. tryck	Max. pressure	Max. Druck	40 bar (DN 15-50), 16 bar (DN 65-150)
Temp. område	Temp. range	Mediumtemp.	-30°C – 180°C

Underhåll / Maintenance / Wartung

Underhållsfri	Maintenance free	Wartungsfrei
Motionering av ventil rekommenderas	Valve exercise is recommended	Ventile Übung wird empfohlen

Kompakt-kulventil med hus av syrafast stål, AISI316. PN 40/16

Compact ball valve in stainless steel, AISI316. PN 40/16

Kompakt-Kugelhahn mit gehäuse aus Edelstahl, AISI316. PN 40/16

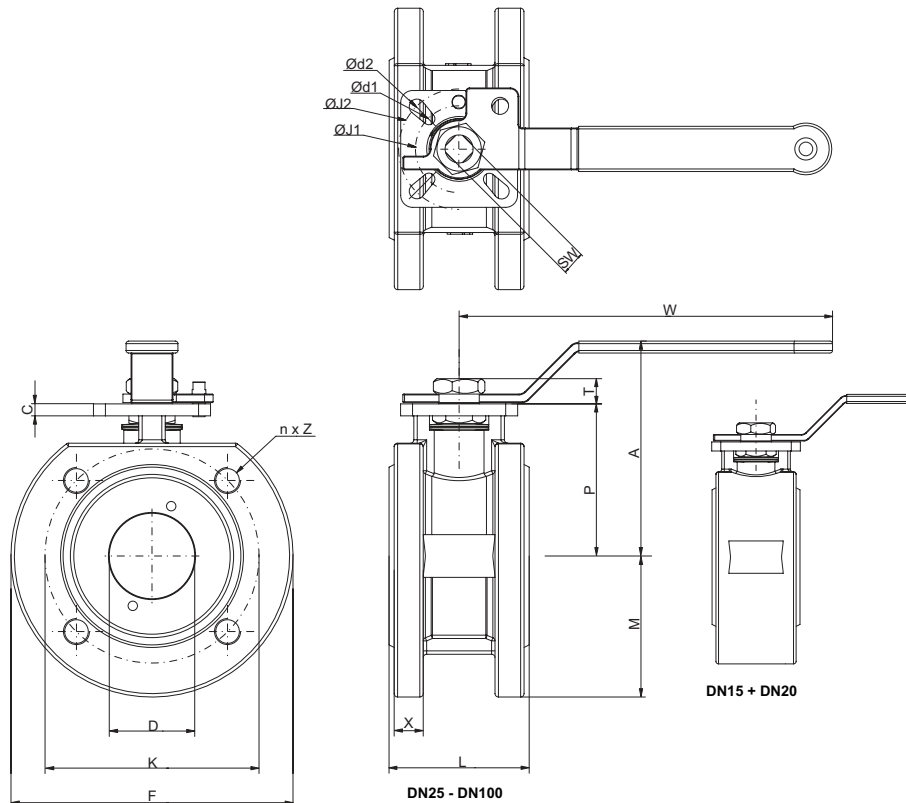

Art. nr	DN	L	X	M	F	K	A	P	T	C	n x Z	W	SW	Ød1	Ød2	ØJ1	ØJ2	Kg
BPS 2461015	15	35	31	47,5	95	65	90,5	54	8	5	4 x M12	115,5	9	6	6	36	-	1,60
BPS 2461020	20	40	36	52,5	105	75	90,5	56	8	5	4 x M12	115,5	9	6	6	36	42	2,20
BPS 2461025	25	46	14	57,5	115	85	102,5	62,5	12	7	4 x M12	188,5	11	6	7	42	50	2,75
BPS 2461032	32	54	14	70	140	100	113,5	72	12	7	4 x M16	188,5	11	6	7	42	50	4,10
BPS 2461040	40	63,5	13	75	150	110	119,5	78	14,8	7	4 x M16	223,5	14	7	9	50	70	4,85
BPS 2461050	50	82	15	82,5	165	125	126,5	87,2	14,8	7	4 x M16	223,5	14	7	9	50	70	7,60
BPS 2461065	65	103	15	92,5	185	145	155,5	107	17,1	11,5	4 x M16	351,5	17	9	11	70	102	10,46
BPS 2461080	80	122	17	100	200	160	166,5	117,3	17,1	11,5	8 x M16	351,5	17	9	11	70	102	13,70
BPS 2461100	100	152	16	110	220	180	181,5	132,3	17,1	11,5	8 x M16	351,5	17	9	11	70	102	19,60
BPS 2461125	125	194	16	135	250	210	204,7	148	47,2	12	8 x M16	400	20	-	M10	-	102	40,00
BPS 2461150	150	234	19	143	285	240	287,0	182	63,0	14	8 x M20	800	26	-	M12	-	125	66,00

Kompakt-kulventil med hus av syrafast stål, AISI316. PN 40/16

Compact ball valve in stainless steel, AISI316. PN 40/16

Kompakt-Kugelhahn mit gehäuse aus Edelstahl, AISI316. PN 40/16

Dimensioner DN 200
 Dimensions DN 200
 Abmessungen DN 200

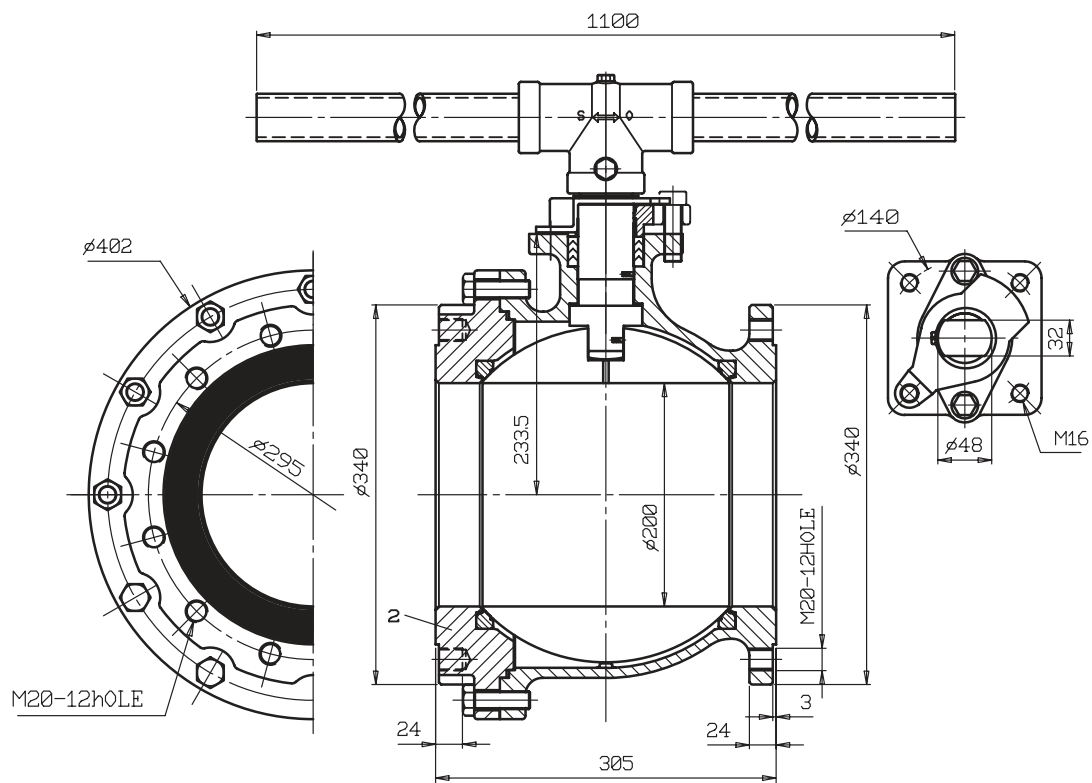

Kompakt-kulventil med hus av syrafast stål, AISI316. PN 40/16

Compact ball valve in stainless steel, AISI316. PN 40/16

Kompakt-Kugelhahn mit gehäuse aus Edelstahl, AISI316. PN 40/16

Sättesmaterial/ Seat material	Material	Beskrivning/Description	Temp. °C	Färg/Color	Anv. område/ Service Appl.	Max. Tryck/ Max. pres- sure
PTFE	Virgin Polyetrafluor- oethylene	Virgin PTFE is the most com- monly used sealing material in ball valves. It is suitable for most medias and has an excellent chemical resistance.	-45°C – 160°C	White	General Chemical	70 bar
R(P)TFE	15% Glass filled reinforced PTFE	15% Glass filled reinforced PTFE has the same good chemical resistance as PTFE but with an improved life cycle and greater pressure rating.	-45°C – 180°C	Off-White	For low and medium pressure service. Steam service up to 150 psig (ca. 10 bar)	140 bar
TFM1600	Modified PTFE (PFA & PTFE)	Second Generation PTFE. Offers lower coefficient of friction and lower torque values. Better defor- mation resistance.	-57°C – 180°C	White	Ideal for applications which require higher purity such as semi- conductor	140 bar
CTFE MG1241	Carbon Graphite Reinforced PTFE	Carbon Graphite Reinforced PTFE is an excellent seat material for steam and thermal services. It has a good abrasion resistance. Due to its high cycling capability it is the recommended soft seat for modulating control applications.	-45°C – 200°C	Black	For high temperature. High pressure for steam service up to 450 psig (ca. 30 bar)	140 bar
MS02 MG1431	MS02 Filled PTFE	Glass and Metal Oxide PTFE filled. Not suitable for food applica- tions.	-45°C – 180°C	Grey	For high temperature. High pressure for steam service up to 450 psig (ca. 30 bar)	140 bar
PEEK	Poly Ether Keton	Poly Ether Keton is a materi- al with outstanding pressure capabilities at high temperatures. It also has an excellent chemical and abrasion resistance.	-45°C – 260°C	Grey	Best suited for high temperature and pressure service up to 3000 psig (ca. 200 bar)	300 bar
DELRIN	Dupont's Acetal Homopolymer (Delrin)	Delrin is capable of handling extremely high pressure. Should not be used in oxygen service.	-40°C – 80°C	Creamy white	Best suited for high pressure service up to 6000 psig (400 bar)	400 bar
UHMW-PE	Ultra High Molecular Weight Polyethylene	UHMW-PE is ideal for use in low level radiation service. This seat also has an excellent resistance to abrasive media. Used in the tobacco industry.	-30°C – 80°C	White	Best suited for abra- sion resistance	350 bar
SS/PTFE	Stainless Powder PTFE	SS/PTFE combines the strenght of metal with the lubricity of PTFE. (50% PTFE and 50% AISI316 powder). This combination pro- vides a higher abrasion, pressure and temperature rating than RTFE	-28°C – 220°C	Grey	Best suited for abrasion and control steam application.	150 bar